

Screw Compressor *Technology*



ALPINE

Alpine Group of Industries was established in early Sixties under the name of Lahore Mughal Steels & started its industrial activity by making ferrous & non-ferrous casting & forgings various industrial applications. In 1970, the company entered into manufacturing business with the oil industry supplied them with equipments & components for oil & gas applications like high pressure valves, pipe line fittings & spare parts of oil & gas industry. In 1986, the company started producing spun pipes. The Defence officers housing colonies, five star hotels, prestigious official buildings & large numbers of private villas & industrial units in Lahore, Islamabad, Peshawar, Quetta & Karachi have used this product in large numbers. Its outlets are located at Lahore, Karachi & Islamabad. By early Nineties, the company had sufficient manufacturing experience to enter into Defence production. The company has the honor of producing very sophisticated Hi Tech Systems & components for the Defence industry. The company earned a name in good quality products in the Army, Air Force & Navy particularly in the area of Armored Personal Carries, Tanks, Weapons Systems & Aerospace industry. Our defence production venture high pressure mobile compressors, APC suspension system, landing gear, depth charge, 25lb bomb, 500lb bomb, fuses, bomb brette signal star, weapon containers etc, now with the joint manufacturing program ALPINE has gone into low & high pressure compressor manufacturing, we have a good list of four valuable clients & our team of experts are available to solve your needs of compressed air / gasses.



ALN 100-3

ALN Series of Screw Compressor covers compressor from 3kw to 132 kw machines. This type of compressor are compact in size & high in reliability.

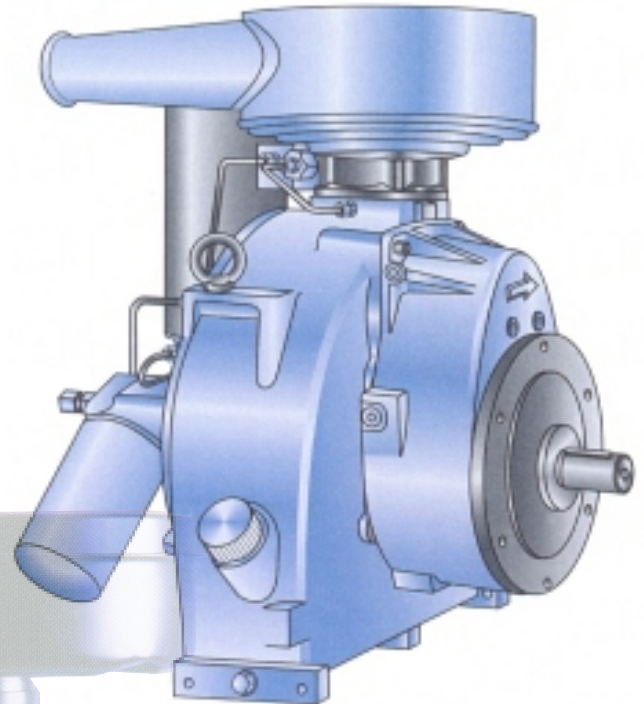

Operating Range

- Power Range.....34Kw
- Capacity Upto.....4.8m³/min
- Pressure Max.....15Bar (can be adjust at 8Bar)
- Speed Max.....8000rpm

Performance Data

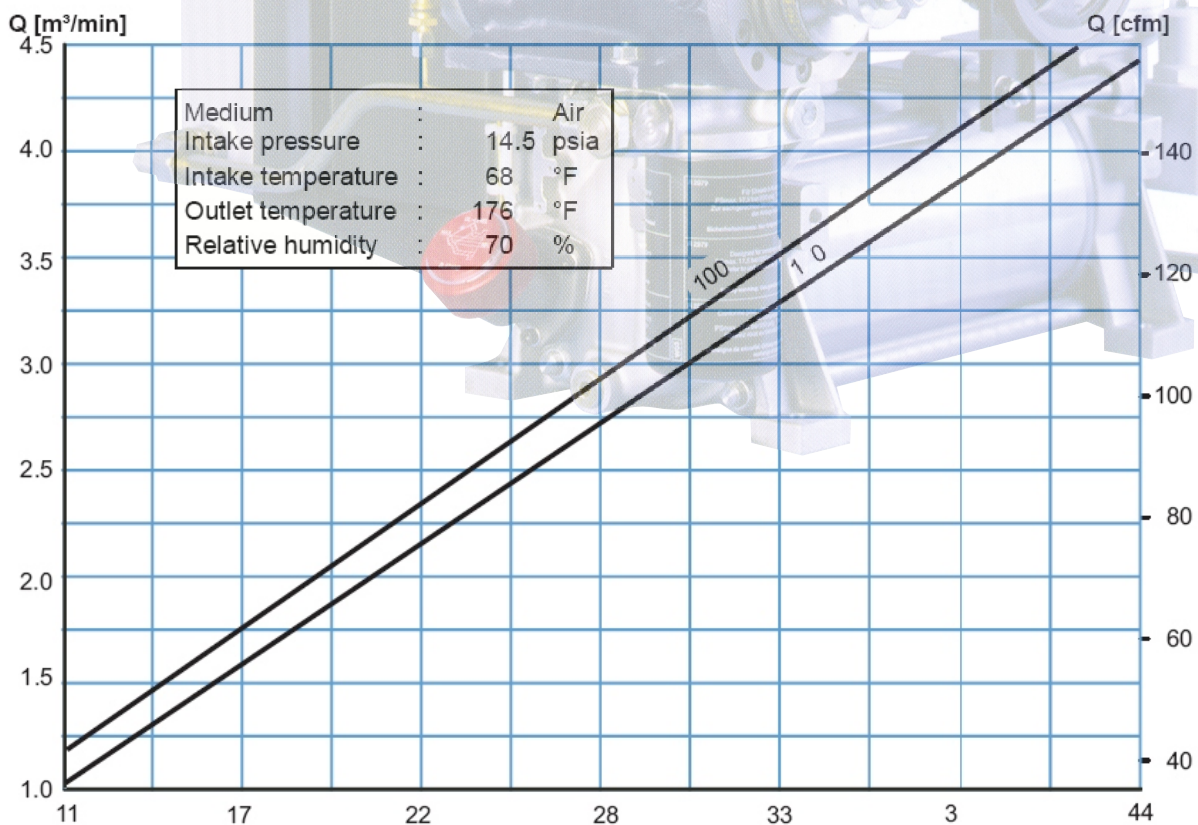

ALN 200

ALN Series of Screw Compressor covers compressor from 3kw to 132 kw machines. This type of compressor are compact in size & high in reliability.

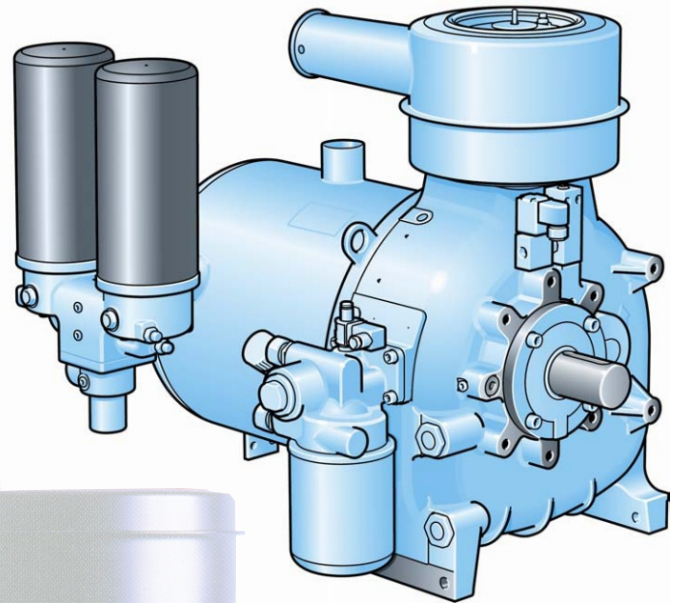

Operating Range

- Power Range.....75Kw
- Capacity Upto.....11.5m3/min
- Pressure Max.....15Bar (can be adjust at 8Bar)

Performance Data

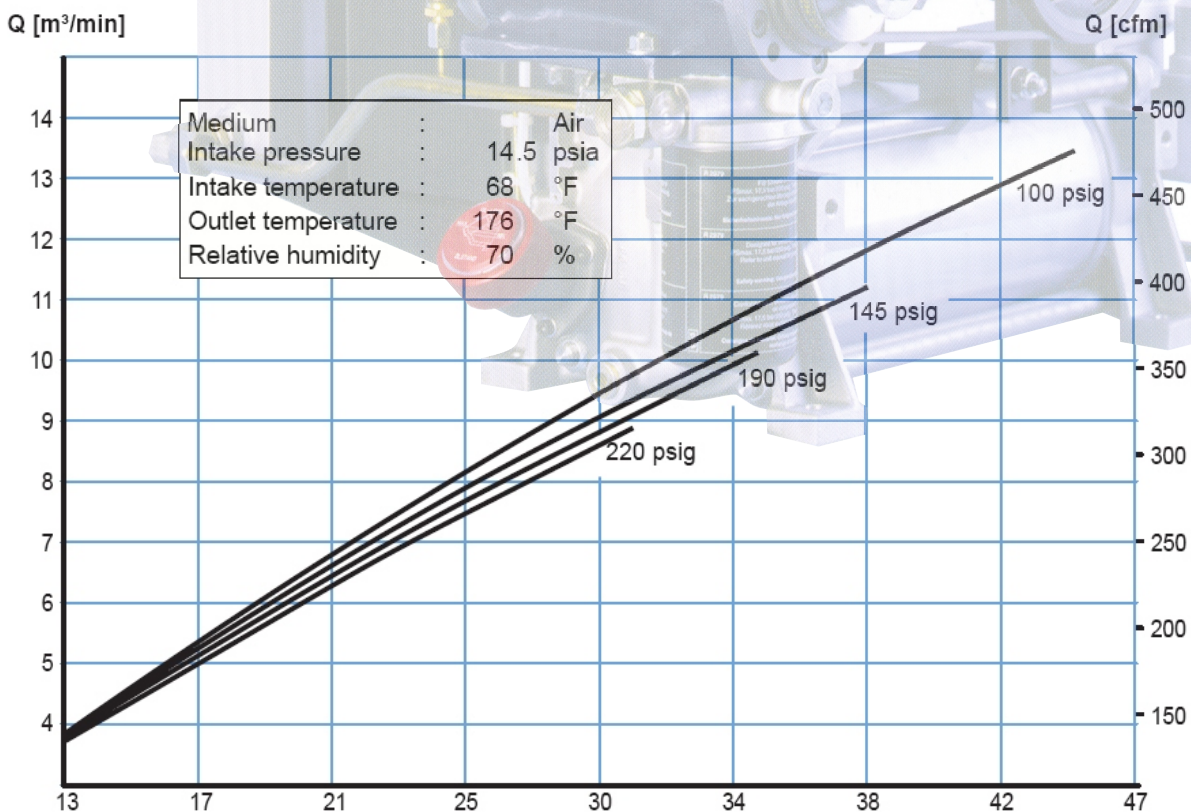

Spare Parts

Original Spares can be order with machine or when required.

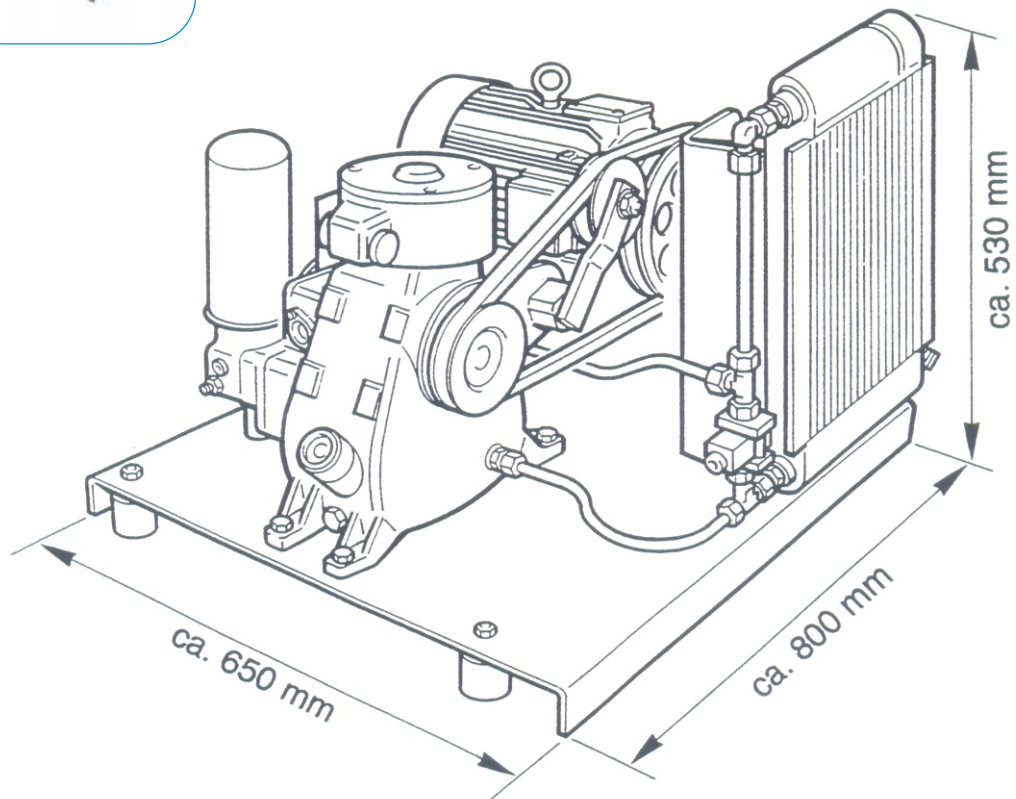
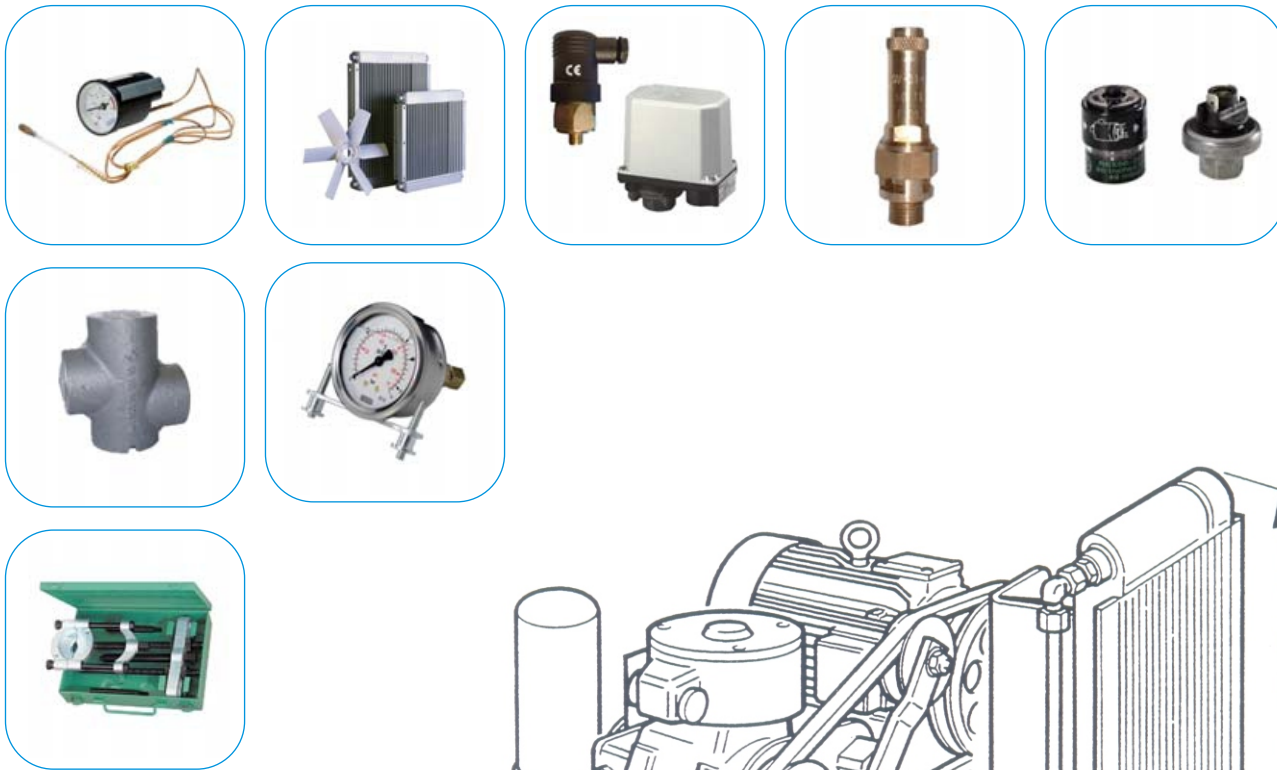

Control (Optional)

A PLC Base control (Siemens) offered for high power machine 40kw & above in order to keep continuous monitoring of system with option to communicate with other system.



Alpine Industrialcon (Pvt.) Ltd.

305/2, G.T. Road, Baghbanpura, Lahore - Pakistan
Tel: +92 42 6852313, 6552910 Fax: +92 42 6553674
www.alpineindustrialcon.com